

# Sector 250 Wire Diagram

The combination of relay, contains the fuse and relay

EFI line even Joint

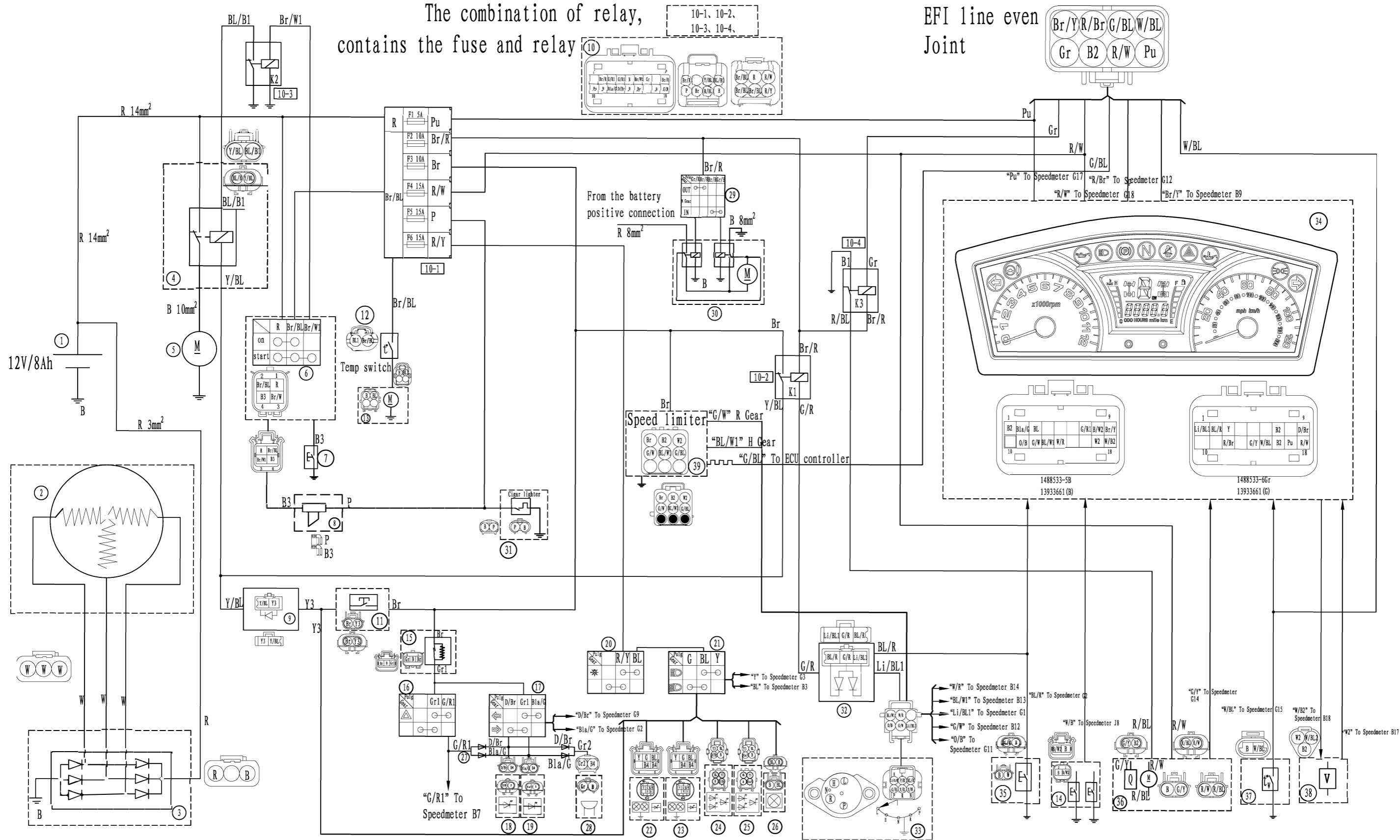

- |                          |                                      |                                       |  |                                 |                              |
|--------------------------|--------------------------------------|---------------------------------------|--|---------------------------------|------------------------------|
| 1, Battery parts         | 9, Brake start dilde                 | 13, Fan motor                         | 21, Low(high beam)convert switch       | 29, Windlass switch             | 37, Water temperature sensor |
| 2, Magnetic motor        | 10, Relay assy.                      | 14, Safety belt lock catch switch     | 22, Head light assy. (L)               | 30, Windlass controller         | 38, The speed sensor         |
| 3, Rectifier/regulator   | 10-1, Fuse                           | 15, Flasher                           | 23, Head light assy. (R)               | 31, DC socket assy.             | 39, Speed limiter            |
| 4, Starter relay         | 10-2, N gear, parking ignition relay | 16, Emergency lamp switch             | 24, Rear brake light assy. (L)         | 32, N gear, parking start dilde |                              |
| 5, Starte motor          | 10-3, Ignition relay                 | 17, Turn light convert switch         | 25, Rear brake light assy. (R)         | 33, Documents show assy.        |                              |
| 6, Ignition switch parts | 10-4, Oil pump relay                 | 18, Front turn signal light assy. (L) | 26, Rear registration plate lamp assy. | 34, Speedmeter part             |                              |
| 7, Horn patr switch      | 11, Brake switch                     | 19, Front turn signal light assy. (R) | 27, Emergency lamp dilde               | 35, Parking final motion switch |                              |
| 8, Horn patrs            | 12, Fan temperature control switch   | 20, Lighting switch assy.             | 28, Buzzer                             | 36, Fuel pump parts             |                              |

Note:  
 R-Red Pu-Purple Li-Light W-White D-Dark Bla-Blackish  
 Br-Brown Y-Yellow BL-Blue B-Black Gr-Grey P-Pink  
 O-Orange G-Green

# Sector 250 ECU Wire Diagram

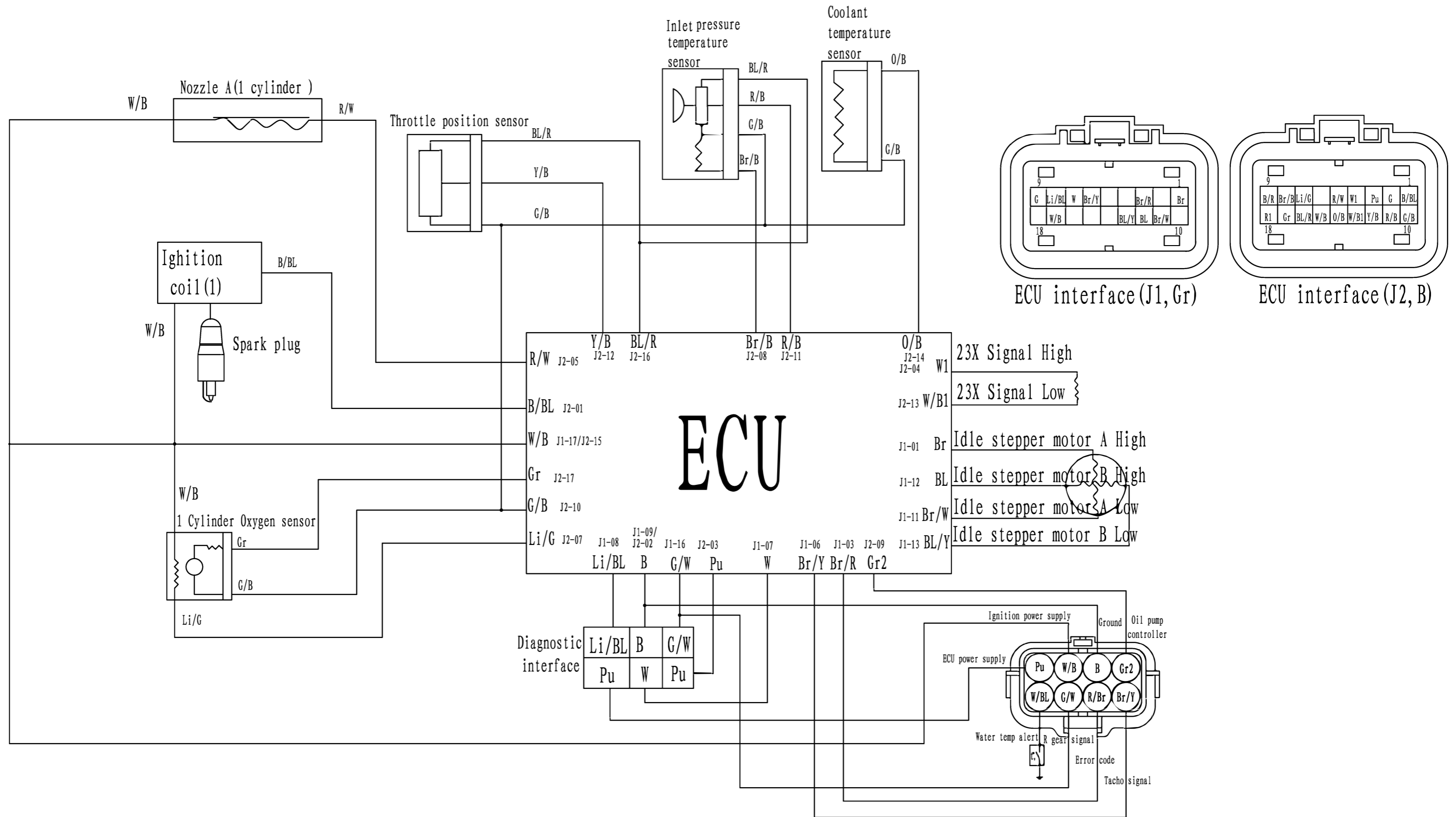

### Sector 250 Ignition Wire Diagram

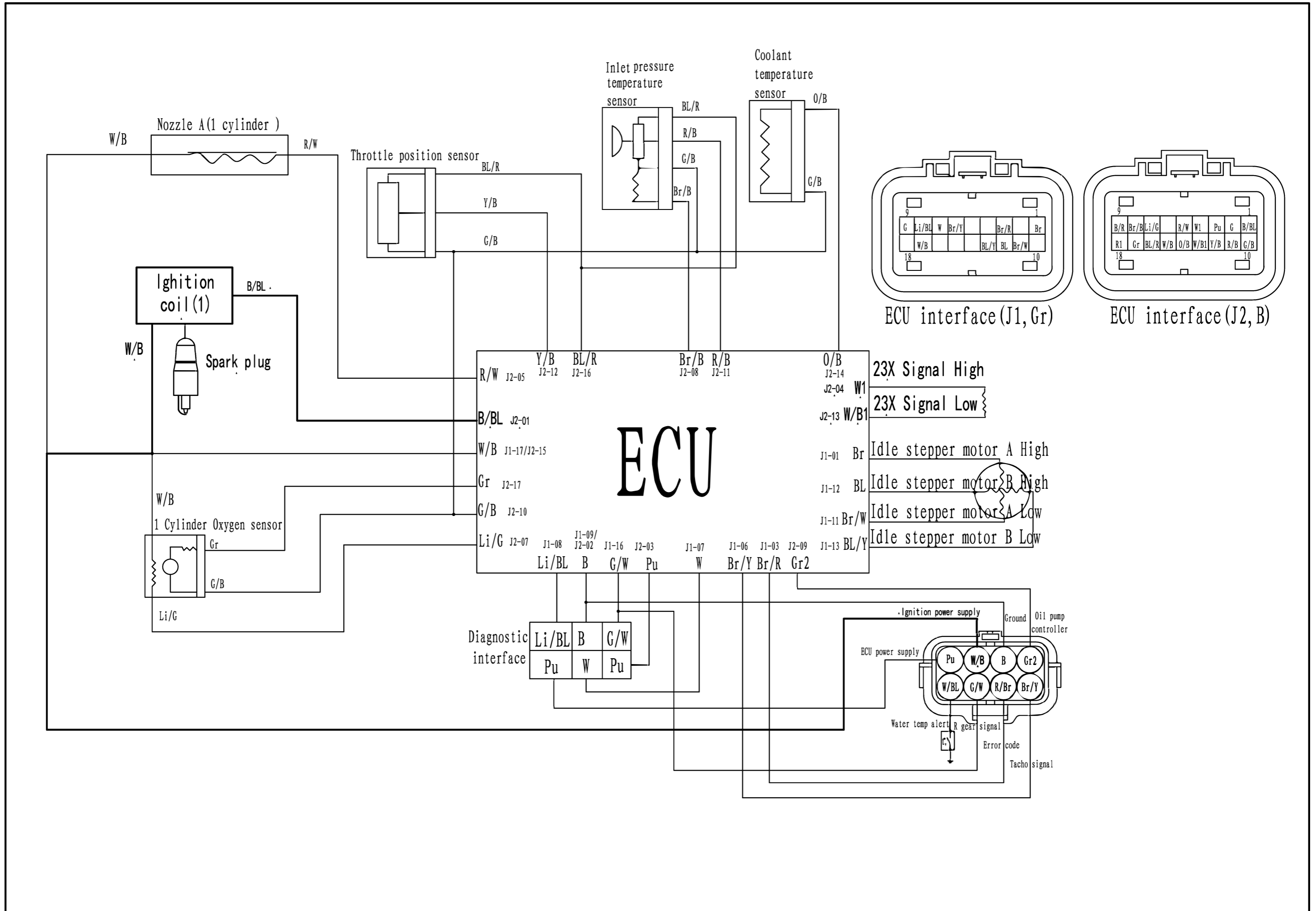

# Sector 250 Starting Wire Diagram

The combination of relay, contains the fuse and relay

10-1, 10-2,  
10-3, 10-4,

EFI line even  
Joint

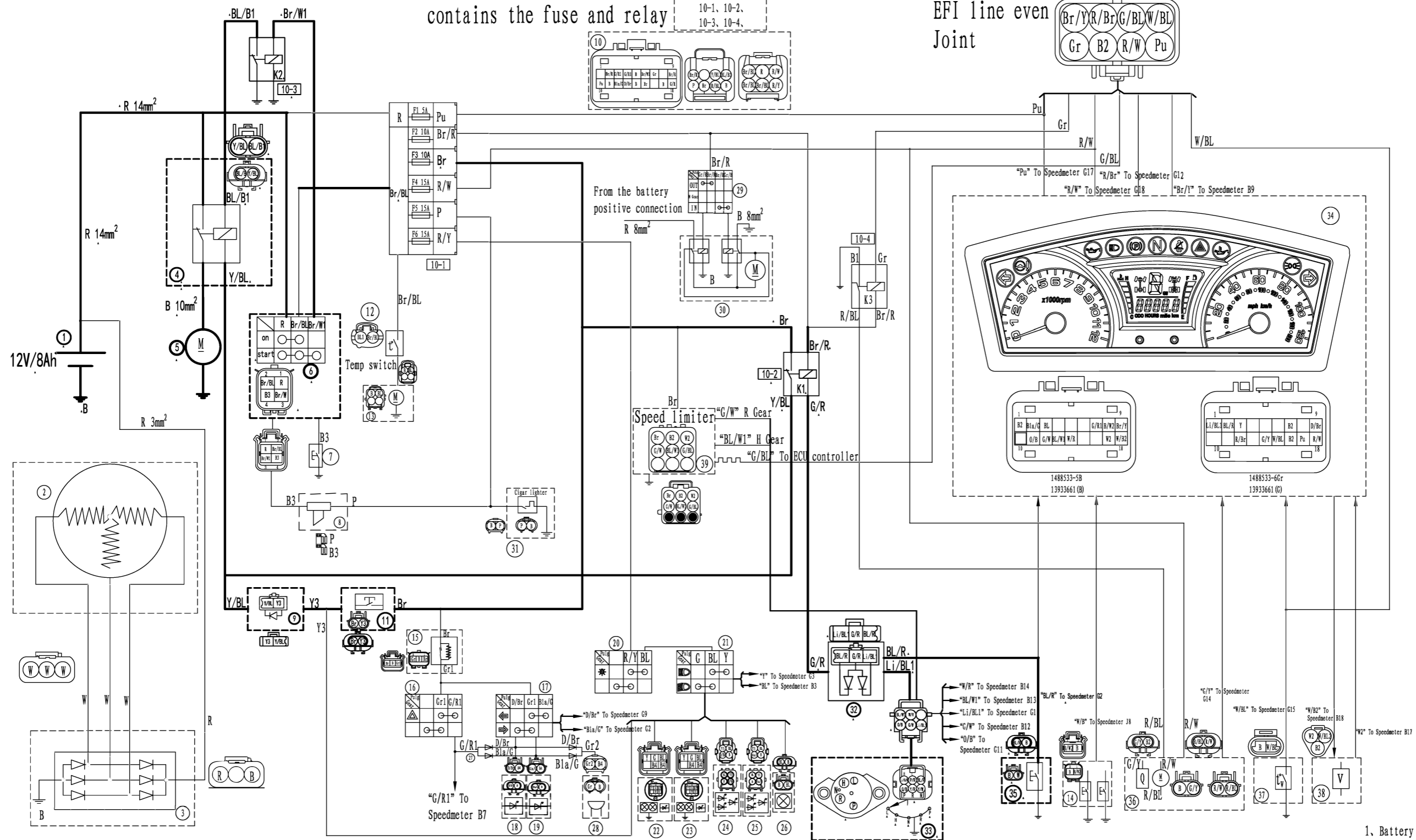
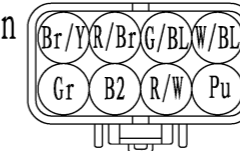

- 1, Battery parts
- 4, Starter relay
- 5, Starter motor
- 6, Ignition switch parts
- 9, Brake start dilde
- 11, Brake switch
- 32, N gear, parking start dilde
- 33, Documents show assy.
- 35, Parking final motion switch

# Sector 250 Lighting Wire Diagram

The combination of relay, contains the fuse and relay

10-1, 10-2,  
10-3, 10-4,

EFI line even  
Joint

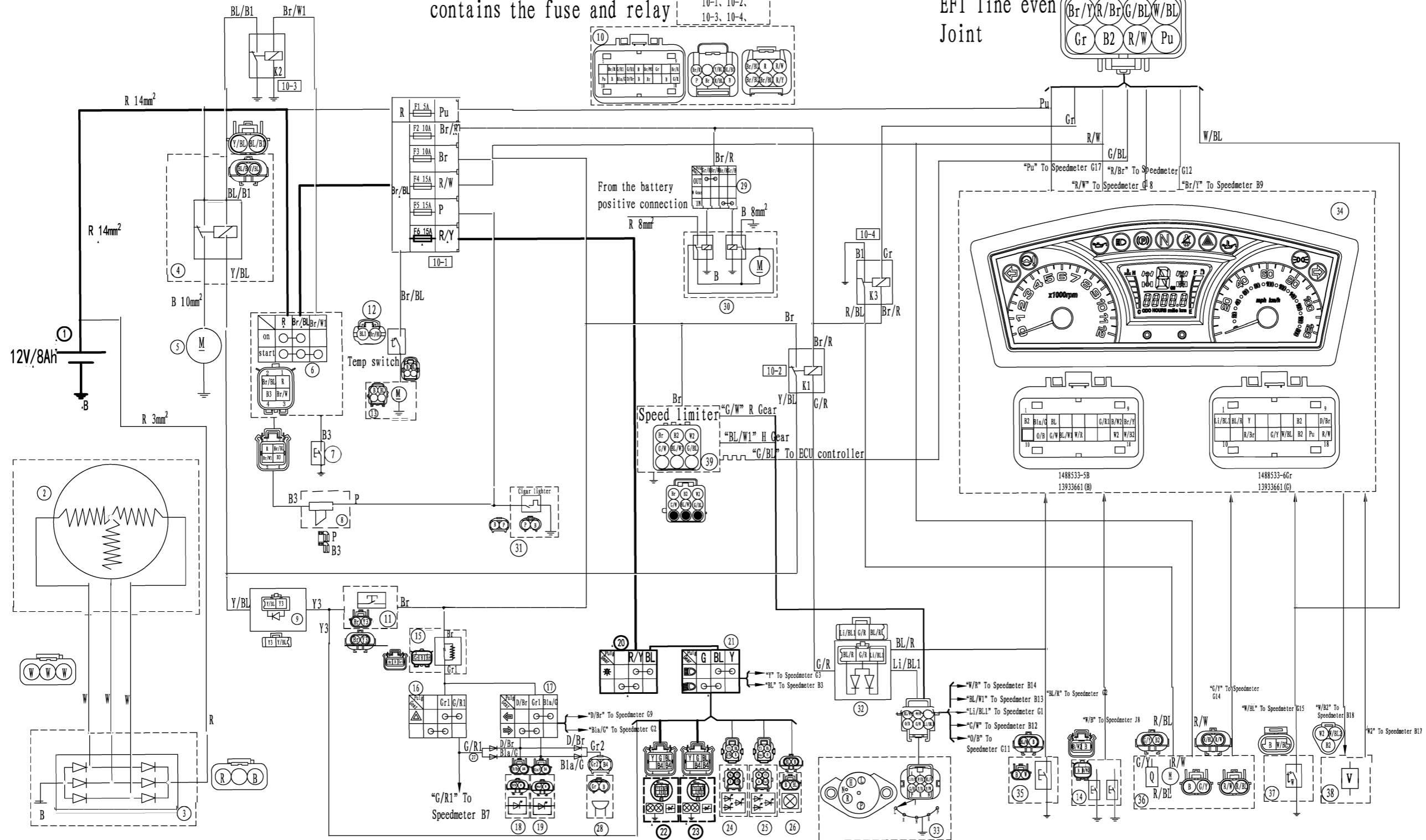
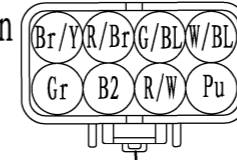

- 1. Battery parts
- 20. Lighting switch assy.
- 22. Head light assy. (L)
- 23. Head light assy. (R)

# Sector 250 Signal Wire Diagram

The combination of relay, contains the fuse and relay

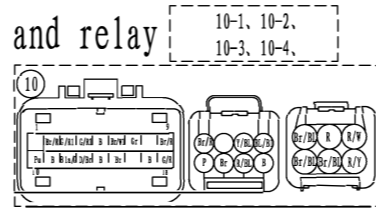

EFI line even Joint

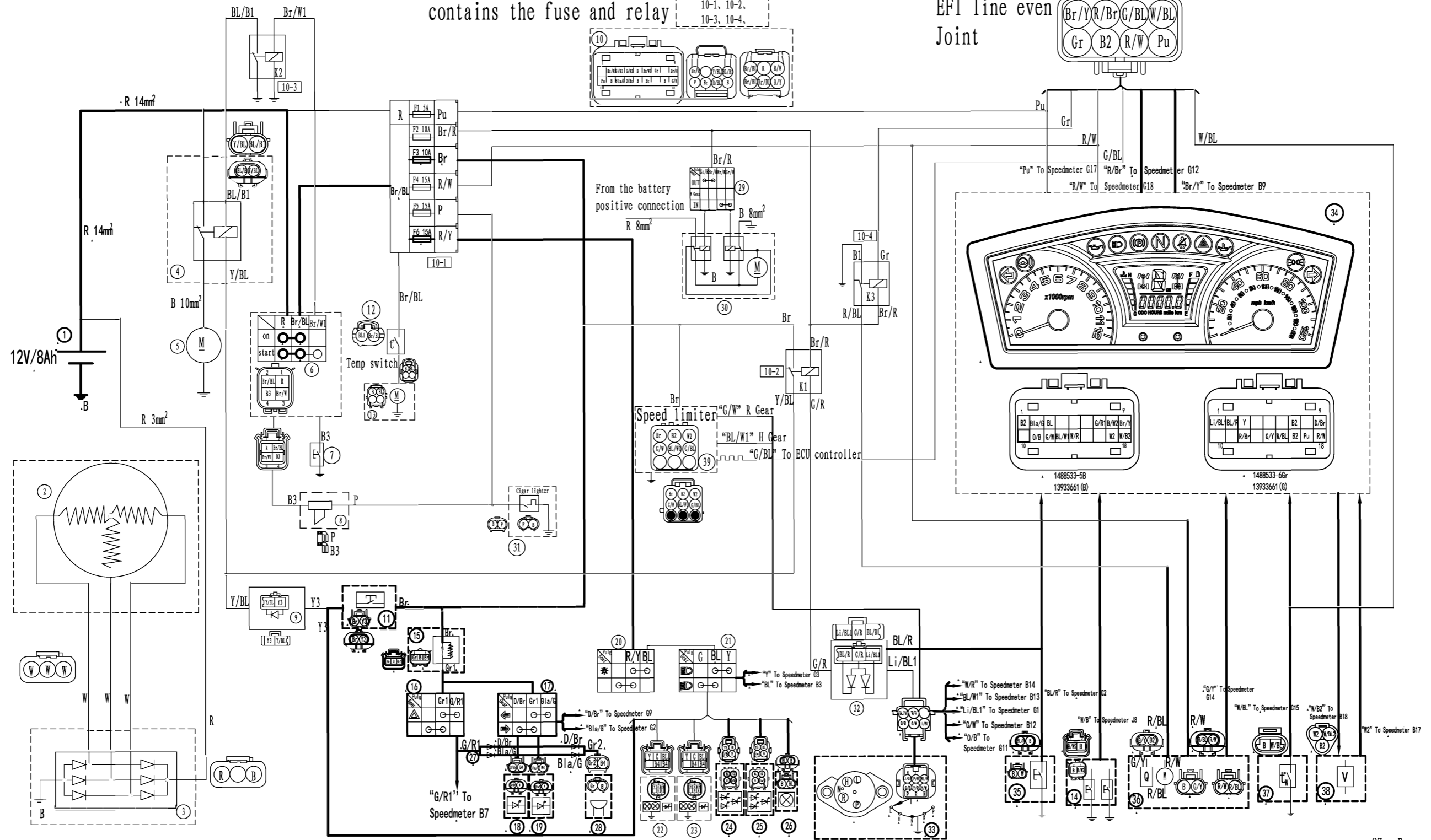
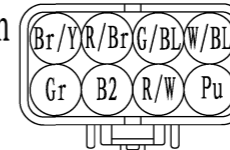

- 1, Battery parts
- 11, Brake switch
- 14, Safety belt lock catch switch
- 15, Flasher
- 16, Emergency lamp switch
- 17, Turn light convert switch
- 18, Front turn signal light assy. (L)
- 19, Front turn signal light assy. (R)
- 24, Rear brake light assy. (L)
- 25, Rear brake light assy. (R)
- 26, Rear registration plate lamp assy.
- 27, Emergency lamp dilde
- 28, Buzzer
- 33, Documents show assy.
- 34, Speedmeter part
- 35, Parking final motion switch
- 36, Fuel pump parts
- 37, Water temperature sensor
- 38, The speed sensor
- 39, Speed limiter